



KH INDUSTRIES

The Permanent Name in Temporary Lighting & Power

PowerTuff™ Festoons

Standard Duty C-Track Manual

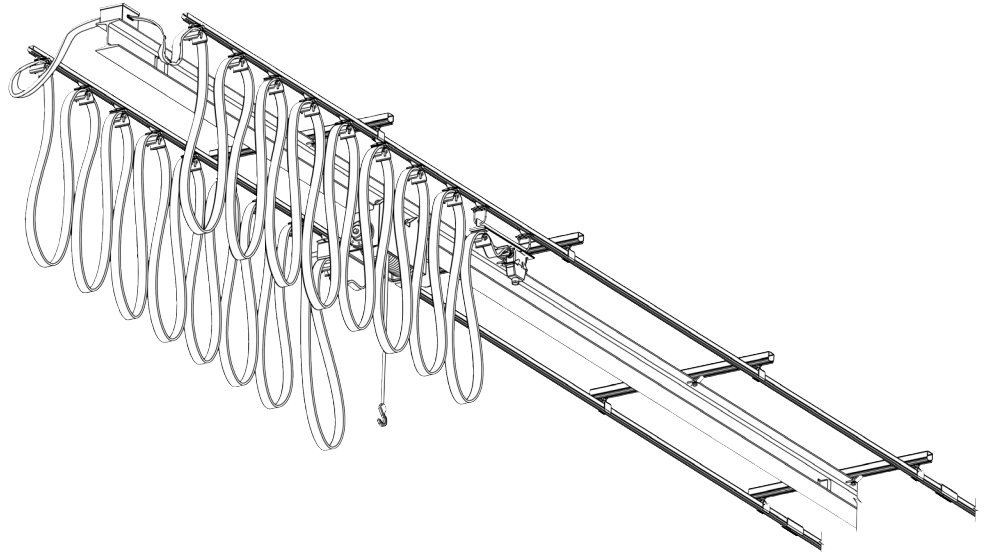

160 Elmview Avenue, Hamburg, New York 14075

Phone: 716-312-0088 - Fax: 716-312-0028
www.khindustries.com - info@khindustries.com



KH Industries Terms and Conditions of Sale

1. **TERMS AND CONDITIONS OF CONTRACT.** Except where otherwise provided in a written agreement duly executed by an authorized signatory of KH Industries, Inc. ("KH"), all goods and services supplied by KH pursuant to the Confirmation of Order overleaf and these terms and conditions (the "Goods") are provided subject to the details set out in the said Confirmation of Order and to the terms and conditions set forth herein. KH's ACCEPTANCE OF AN ORDER IS EXPRESSLY CONDITIONED UPON BUYER'S ASSENT TO THESE TERMS AND CONDITIONS, AND BUYER'S ACCEPTANCE OF GOODS HEREUNDER SHALL BE DEEMED AN ACCEPTANCE OF THESE TERMS AND CONDITIONS. KH specifically rejects any terms and conditions in Buyer's order or in any other document from Buyer that in any way conflict with, reduce or affect these terms and conditions.

2. **PRICES.** Unless otherwise agreed in writing, all prices are quoted F.O.B. at KH's premises in Hamburg, New York, USA. All price quotes by KH will remain valid for thirty (30) days. Thereafter, prices are subject to change without notice to Buyer. Typographic, clerical and manifest errors in any offer are subject to correction by KH at any time. The minimum billing per order is \$100 plus freight charges, orders that do not meet this minimum will be subject to a \$25 service charge.

3. **PAYMENT TERMS.** Payment for all Goods shall be made prior to shipment (either by cash, banker's draft, cashier's check, check drawn on good funds, telegraphic transfer or approved credit card) or, at the sole discretion of KH, C.O.D., unless Buyer has applied for and been granted a line of credit by KH, in which case purchases can be made up to approved credit limits with payment therefore due net 30 days. Late payments shall be charged interest at the rate of 1.5% per month. KH is entitled hereunder to delay shipment until payment monies have cleared (e.g. check has become final; credit card charge has been authorized). Credit terms are subject to change or withdrawal at any time at KH's sole discretion, regardless of prior credit arrangements. KH reserves the right to require current financial information from any buyer with an open account as a condition of the continued extension of credit. Buyer shall promptly reimburse KH in respect of KH's costs, including reasonable attorneys' fees, incurred in the collection of any monies owed to KH by Buyer. For orders invoiced or shipped outside the United States, KH will require a confirmed, irrevocable letter of credit, payable at sight in United States funds, advised and payable on an acceptable US bank. Buyer shall be solely responsible for procuring any and all necessary export, import and/or other permits. Buyer's order shall constitute a representation that Buyer is solvent, and KH is relying upon such representation. If KH at any time reasonably believes that the Buyer is insolvent or that the Buyer's credit is impaired, Buyer shall be in material breach thereof and hereof and KH may, without liability to Buyer, withhold performance hereunder, change the payment terms and/or repossess Goods delivered.

4. **ADDITIONAL COSTS & TAXES.** All prices and quotations are exclusive of sales, use, excise, duty, VAT and all similar taxes and levies. All such charges shall be for the account of Buyer and, if not included in an original invoice, may be invoiced or added to Buyer's credit card payment, if any, by KH at a later date.

5. **CHANGES; CANCELLATION OF ORDER.** If Buyer cancels or changes the order, or any part thereof, for any reason, Buyer agrees to pay cancellation charges for all costs incurred by KH due to such cancellation, including without limitation, costs incurred by KH in the design, development or manufacture of special, custom-made or custom-designed Goods, or goods altered at the request of Buyer, [plus related profit.] The costs shall include commitments made by KH to third parties for labor or materials for use in completing such order. KH's determination of cancellation charges shall be final and conclusive.

6. **SHIPPING.** Title in Goods and risk of loss or damage thereto shall pass to Buyer upon delivery thereof by KH to the carrier at FOB point. Goods shall be shipped in accordance with the information set out in the Confirmation of Order overleaf. Unless instructed otherwise by Buyer, KH may ship by any reasonable manner and routing. All shipping costs shall be for the account of Buyer. All shipments shall be insured for

their full replacement value and all such insurance shall be for the account of Buyer. [All orders are subject to KH's current shipping and handling charges.] KH shall not be liable or otherwise responsible for defaults or delays in delivery by carrier. Shipping dates set out on the Confirmation of Order are approximations only, subject to, inter alia, factory schedules and inventory. If any shipment of Goods is delayed due to any act or omission of Buyer, KH may charge Buyer reasonable storage fees in relation thereto, including without limitation, storage costs, insurance costs and cost of money. Unless otherwise agreed by KH in writing, KH, in its sole discretion, may make partial shipments of any order, for which pro rata payments shall be due and payable as indicated on the invoice issued pursuant thereto. KH reserves the right not to ship to Buyer if Buyer's account is overdue.

7. **ACCEPTANCE OF GOODS.** Buyer acknowledges that it has a duty to inspect Goods immediately upon receipt. Goods will be deemed accepted by Buyer unless notice of lawful rejection has been delivered in writing to KH within ten (10) business days after receipt thereof. Any notice of shortage must be delivered in writing to KH within three (3) business days after receipt thereof by Buyer. Any notice of damage to Goods must be delivered in writing to KH and the relevant carrier within three (3) business days after receipt thereof by Buyer. Authorization from KH must be received by Buyer in writing prior to the return of any Goods by Buyer hereunder, and Buyer shall be solely responsible for adequate packing and pre-payment of freight with respect thereto. For the avoidance of doubt, KH shall not be obligated to accept any unauthorized return of Goods, any Goods inadequately packed or Goods for which freight has not been fully pre-paid by Buyer.

8. **RETURNED GOODS.** KH may, at its sole option, agree to accept unused and merchantable Goods from Buyer, subject always to a re-stocking charge of 20%. Buyer agrees that it shall not return any Goods prior to receiving written authorization from KH so to do. Any and all returned Goods shall be shipped freight pre-paid and risk of damage or loss shall remain vested in Buyer until the relevant Goods are received, inspected and accepted by KH. For the avoidance of doubt, KH is not obligated to accept any returned Goods pursuant to this paragraph. Custom manufactured Goods are non-cancelable/non-returnable.

9. **RE-CONDITION & REPAIR.** Before shipping any Goods to KH for such repair, Buyer shall contact KH for Return Merchandise Authorization (RMA), and shipping instructions. With respect to any repairs by KH, Buyer shall be solely responsible for payment of freight charges, replacement parts, and labor costs at KH's then current prices. Any repairs to any of the Goods performed by Buyer or by third parties [pre-approved by KH] shall be carried out in strict accordance with the applicable repair manual(s), if any, published by KH from time to time.

10. **LIMITED WARRANTY; EXCLUSION OF OTHER WARRANTIES; LIMITATION OF REMEDIES; INDEMNITY.** KH warrants the Goods to be free from defects of materials or workmanship, under normal and proper use and service, for a warranty period of one (1) year from the date of shipment. If any of the Goods proves to be defective in material or workmanship within said warranty period, such Good(s) shall be promptly returned to KH, shipping charges prepaid, and if the same is determined by KH to be defective in material or workmanship, it will be replaced or repaired, at the exclusive election of KH, free of charge, F.O.B. KH's factory. If Buyer discovers that the Goods, or any of them, do not conform to the warranty specified hereinabove, Buyer shall immediately [cease using such Good(s) and] notify Seller in writing of such non-conformity, specifying in reasonable detail the nature thereof.

THIS WARRANTY IS MADE AND ACCEPTED IN LIEU OF ALL OTHER WARRANTIES, EXPRESS OR IMPLIED, WHETHER OF MERCHANTABILITY OR OF FITNESS FOR A PARTICULAR PURPOSE OR OTHERWISE, AS BUYER'S EXCLUSIVE REMEDY FOR ANY DEFECTS IN THE GOODS, AND ALL OTHER REMEDIES ARE EXPRESSLY DISCLAIMED.

No warranty is made by Seller for consumables or for normal wear and tear, or for Goods which have been set up, operated and/or installed other than in strict accordance with KH's

written instructions; or which have been subjected to improper installation, misuse, negligence or accident; or which have been serviced, repaired or altered improperly or by anyone other than Seller [or Buyer or third party approved by Seller, in strict accordance with the applicable repair manual(s), if any, published by KH from time to time]; or which have been used in a manner or for a purpose for which the Goods were not designed. No warranty is made with respect to any defects in the Goods due to plans or instructions supplied to Seller by or for Buyer. All other obligations and liabilities of Seller, whether directly or by way of indemnity, for special, incidental, consequential or other damages, whether based on breach of contract, warranty, tort (including negligence), strict products liability, patent or trademark infringement, or any other theory in connection with the purchase or use of the Goods, are expressly EXCLUDED. In no event will Seller be liable on any claim that Goods are defective for an amount in excess of the price paid by Buyer for the Goods. Buyer hereby expressly assumes all risk as to the suitability, performance quality and compatibility of the Goods, and in this respect the product is being provided on an "AS IS" basis. [Buyer acknowledges that some of the Goods might be used in inherently dangerous activities and, accordingly, expressly bears the risk of injury, damages and other harm to itself and to third parties arising out of use of any of the Goods in such inherently dangerous activity(ies).] Furthermore, Buyer agrees to indemnify, hold harmless and keep indemnified KH for any claims, awards, damages or other costs incurred by KH, including reasonable attorneys' fees, arising out of the use of any Good(s) in inherently dangerous activities.] While KH uses reasonable endeavors to ensure the accuracy and quality of its publications, sales literature and other printed materials, from time to time errors might occur in that regard. KH therefore does not guarantee the accuracy or completeness of any publication or other informational materials.

11. **INTELLECTUAL PROPERTY.** The purchase by Buyer of any Goods hereunder does not grant to, convey or confer upon Buyer or Buyer's customers, or upon anyone claiming under Buyer, a license or any other legal interest, express or implied, under any patent right, trademark, copyright or other intellectual property right, whether registered or not and whether pending or not, in any jurisdiction, of KH covering or relating to any of the Goods or any combination or process in which any of the Goods might be or are used.

Buyer understands and agrees that KH does not warrant that the Goods are free of claims of patent, trademark, trade secret or copyright infringement by a third party. KH hereby disclaims any such warranties or indemnification for such infringement(s) or intellectual property rights.

Any rights not expressly granted herein are reserved by KH.

12. **FORCE MAJEURE.** KH shall not be liable for any failure to perform under the Confirmation of Order or these terms and conditions if it is unable to obtain parts or supplies at reasonable prices or through usual and regular sources on a timely basis, or due to any interruption of transportation, government regulation, labor disputes, strikes, riots, war, civil commotion, fire, flood, accident, storm, or act of God, or other cause beyond KH's reasonable control that renders it impractical for KH to perform.

13. **GENERAL.** This Agreement will be governed by and construed in accordance with the laws of the State of New York. The application of the United Nations Convention for the International Sale of Goods, if it would otherwise apply, is hereby expressly excluded. These terms and conditions and the Confirmation of Order overleaf set out the entire agreement between KH and Buyer relating to the Goods and supersede any prior agreement, arrangement, purchase order, correspondence, communication, advertising or representation concerning the Goods. This Agreement may not be modified or amended except by a written instrument duly executed by authorized signatories of the parties. If any provision of this Agreement is held to be invalid or unenforceable, that provision is to be given effect to the maximum extent permissible and the remaining provisions of this Agreement will remain in full force and effect. Notices hereunder shall be delivered in writing by registered mail to the addresses of the parties overleaf, or as notified to the other party from time to time.

- 1.0 Specifications
- 2.0 Safety
 - 2.1 Electrical Warnings
 - 2.2 Operational Warnings
 - 2.3 Maintenance Warnings
- 3.0 Tools List
- 4.0 Installation
 - 4.1 Track Hanger Installation
 - 4.2 Track Joint Assemblies Installation
 - 4.3 Anchor Clamp Installation
 - 4.4 Girder Clamp Installation
 - 4.5 End Clamp Installation
 - 4.6 Cable Trolley Installation
 - 4.7 Tow Trolley/Control Box Trolley Installation
 - 4.8 End Stop Installation
 - 4.9 Installation of Cables
 - 4.10 Tow Webbing Installation
 - 4.11 Tow Bar Installation
- 5.0 Operation
 - 5.1 Pre-Operation Inspection
 - 5.2 Operational Instructions
- 6.0 Maintenance
 - 6.1 Maintenance Instructions

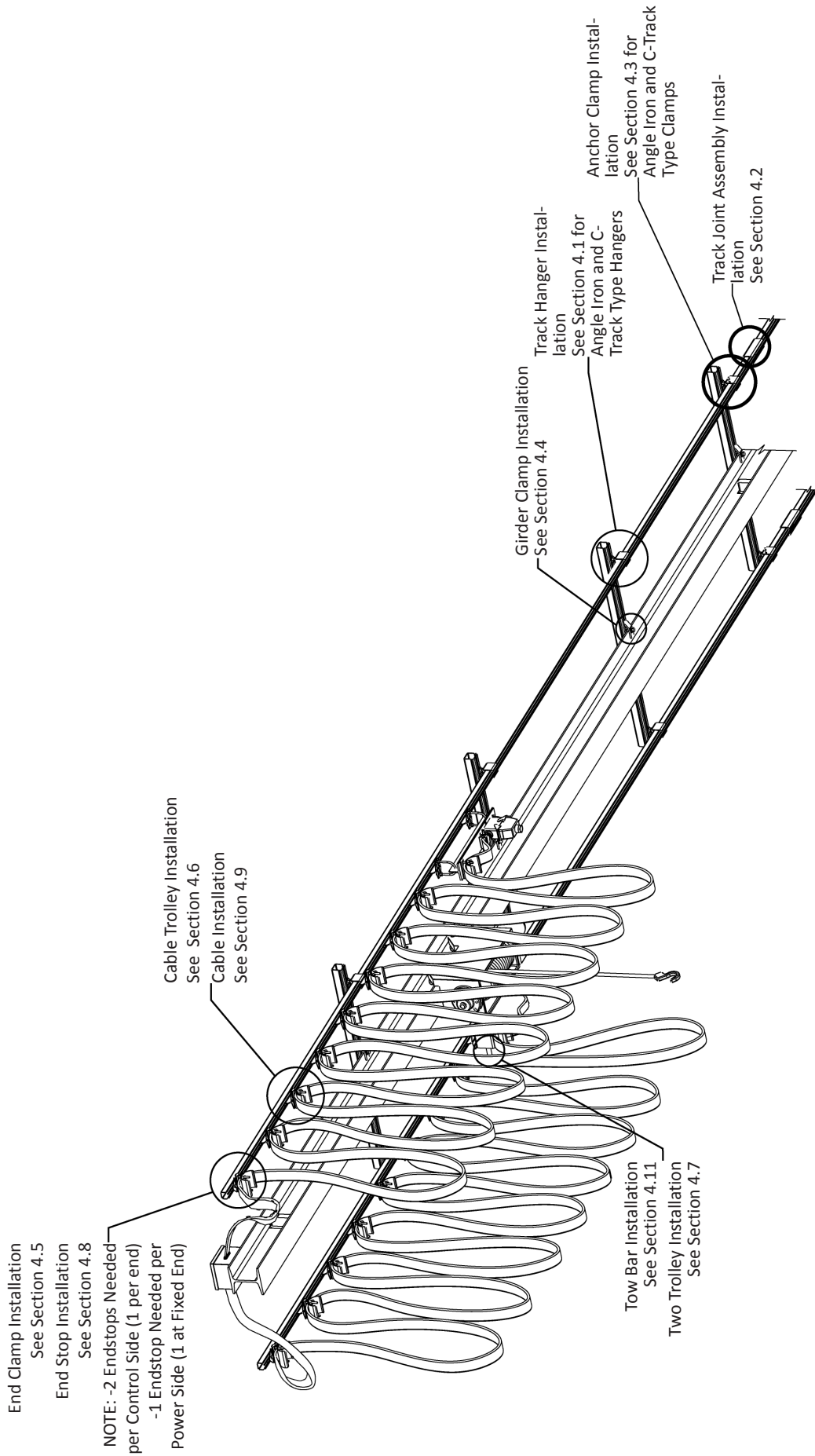

1.0 Specification

- 1.1 Maximum trolley speed is 250 fpm.
- 1.2 Maximum load per trolley is 40 lbs.
- 1.3 C-Track material is 16 gauge galvanized or stainless steel. Loop depth of 3 ft. is typical unless otherwise specified.
- 1.4 The loop depth is the distance from the top of the track to bottom of the cable loop.
- 1.5 The minimum curve radius is 4 ft. Consult our Sales Team for loop depth requirements on curves.
- 1.6 Maximum cable thickness is 1.38"
- 1.7 Usable saddle width on cable carrier is 2.13"

2.0 Safety

2.1 Electrical Warnings

- 2.1.1 Properly ground all electrical connectors in accordance with the National Electric Code, local codes, and ordinances.
- 2.1.2 Disconnect and LOCK OUT / TAG OUT the electrical power from the system before any service is performed.
- 2.1.3 Do not use cable for loads greater than the voltage and current rating. The capacity rating of the cable should be in accordance with the National Electric Code.

2.2 Operational Warnings

- 2.2.1 Exercise care when handling the festoon system during normal operation.
- 2.2.2 Do not use cable different for which the system is intended. Change in diameter, weight per foot, length or flexibility of cable will affect the operation of the system.
- 2.2.3 Mounting hardware and fasteners should be installed to maintain tightness under vibration and checked periodically to insure tightness.

2.3 Maintenance Warning

- 2.3.1 **WARNING:** Modification of this equipment may cause excessive wear and will void the warranty. Contact KH Industries regarding changes or modifications to this equipment.

3.0 Tools List

3.1 Recommended Hand Tools

- a) Socket Wrench
- b) Torque Wrench
- c) 1/4" Open / Box End Wrench
- d) 10 mm Open / Box End Wrench
- e) 7/16" Open / Box End Wrench
- f) 1/2" Open / Box End Wrench
- g) 13 mm Open / Box End Wrench
- h) 9/16" Open / Box End Wrench
- i) 1/8" Allen Wrench
- j) Flat Screwdriver
- k) Drill and Drill Bit Set

4.0 Installation

4.0.1 Standard Duty "C" Track festoon systems are light duty systems suited for cranes and hoists usually with lighter duty cycles.

4.0.2 Locate longitudinal center line of runway where channel is to be installed.

4.0.3 If the C-Track is to be attached under a beam or stud, the hanger locations should be marked and drilled, or cross arm support installed.

4.1 Track Hanger Installation

(10mm or 13mm Open / Box End Wrench Required depending upon hanger)

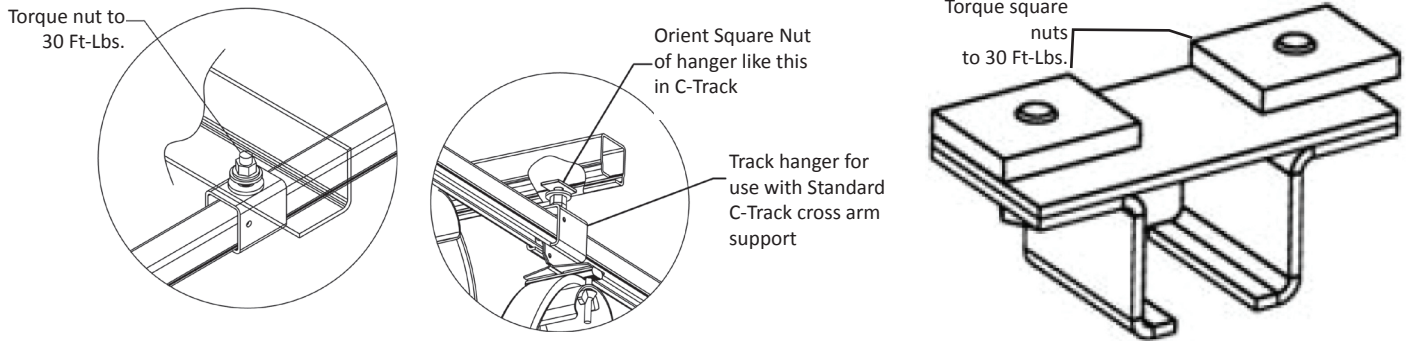

4.1.1 The track hanger is designed to be mounted on angle iron brackets with one mounting hole. (can be mounted on c-track cross-arm support or other suitable structures) One track hanger is required for each cross arm support bracket for each track run at 5 ft. spacing. Extra track hanger and cross arm support bracket is required in storage area.

4.1.2 Slip the appropriate number of hangers on each section of C-Track (2) for a 10' section and (4) for a 20' section of C-Track. Torque nuts to 30 Ft-Lbs.

4.1.3 Bolt the section loosely in place, joining the ends of the channels with splice joints as you progress.

4.2 Track Joint Assemblies Installation

(10mm Open / Box End Wrench Required)

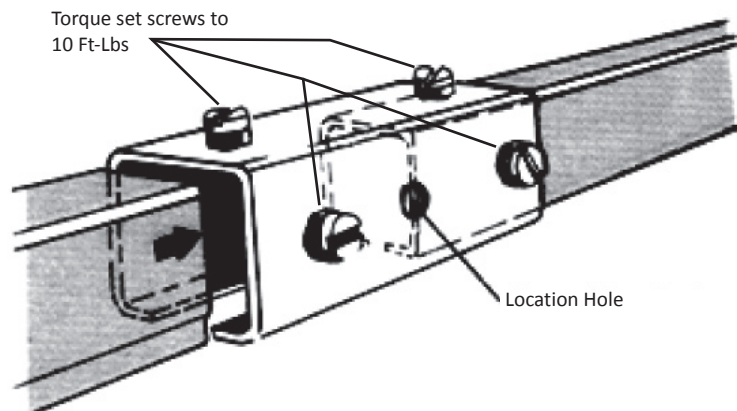

4.2.1 Track joints clamp for secure attachment and proper alignment of track section. Each kit includes four set screws and nuts.

4.2.2 Install the joints and tighten fasteners using a 10mm Open / Box End Wrench..

4.0 Installation

4.3 Anchor Clamp Installation

(9/16" & 7/16" 10mm & 13mm Open / Box End Wrench Required)

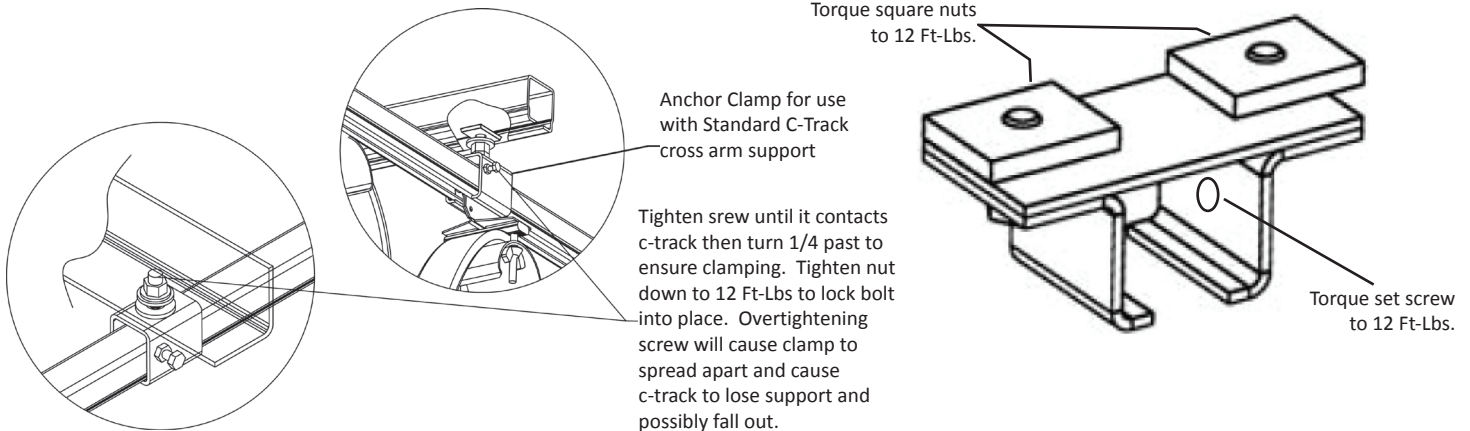

4.3.1 Anchor clamps are designed to hold the track in place while allowing free expansion of the system due to temperature changes. One anchor clamp is required per run and should be placed as close to the center of the system as possible.

4.3.2 In the center of the system, place an Anchor Clamp instead of a Track Hanger Clamp to anchor the system. The C-Track is now positioned into place.

4.4 Girder Clamp Installation

(1/2" & 13mm Open / Box End Wrench Required)

4.4.1 Girder clamps are designed to hold the cross-arm supports to the I-beam. Two girder clamps required per cross-arm support.

4.4.2 Weld on suspension support bracket

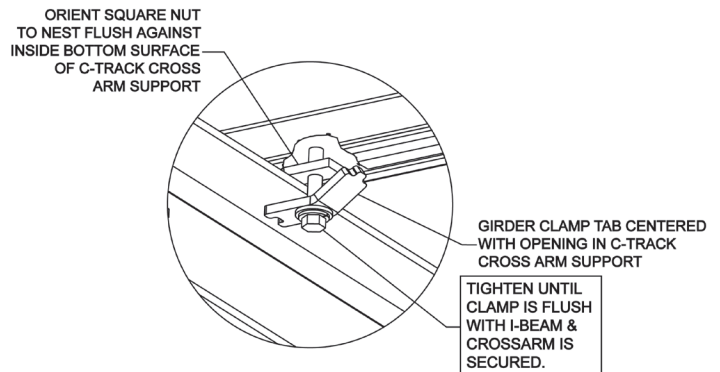
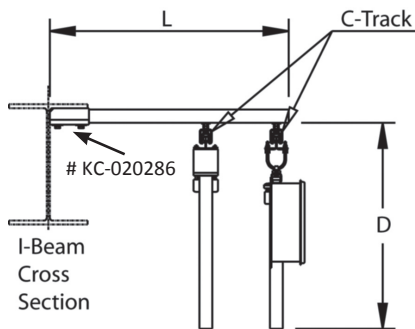

4.5 End Clamp Installation

(1/2" 10mm Open / Box End Wrench Required)

4.5.1 The End Clamp is the first cable carrier at the fixed end of the festoon system. The "End Clamp" will always be the stationary component of the festoon system and does not have wheels. Typically only one is required per system.

4.5.2 Install the end clamp assembly at the far end of the fixed end of the C-Track and tighten fasteners to 11 ft.-lbs.

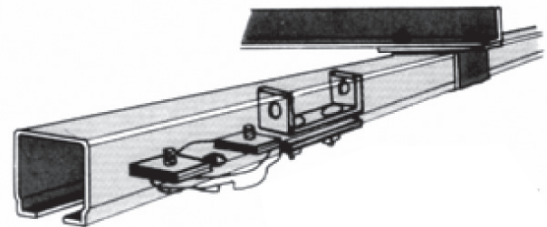

4.0 Installation

4.6 Cable Trolley Installation

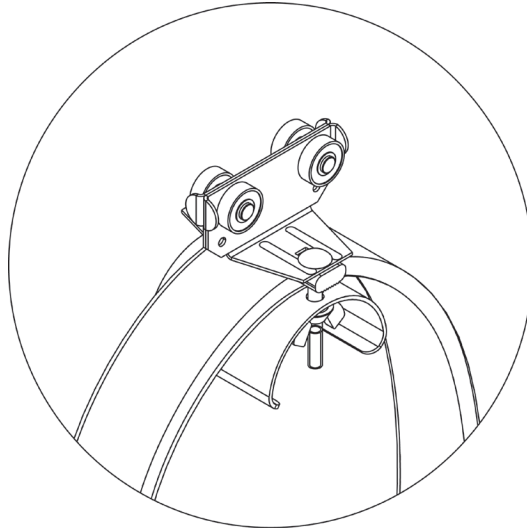

4.6.1 **WARNING - DO NOT INSTALL TROLLEYS IN THE C-TRACK UNTIL ALL HANGERS AND SPLICES ARE SECURELY FASTENED TO THE RECOMMENDED TORQUE.**

4.6.2 The cable Trolley is the device with rollers that rolls inside the C-Track and carries the electrical cable down the track.

4.6.3 With the channel securely located, install the carriers into the slot of the C-Track. Place all trolleys into the track.

4.7 Tow Trolley / Control Box Trolley Installation

4.7.1 The Tow Trolley is the first cable carrier at the mobile end of a power festoon system. The Tow Trolley attaches to the crane power consumer usually with a tow arm.

4.7.2 The Control Box Trolley is the first mobile carrier at the mobile end of a control festoon system. The Control Box Trolley consists of a mobile junction box or a quick disconnect connector to which a push button pendant may be wired.

4.7.3 Place the Tow Trolley / Control Box Trolley into C-Track the same as the Cable Trolleys.

TOW BAR SHOULD BE CENTERED
TOP TO BOTTOM IN TOW BOX,
THIS ALLOWS FOR A FREE RANGE OF
MOVEMENT FOR THE CRANE
OR SYSTEM THAT IS BEING ELECTRIFIED

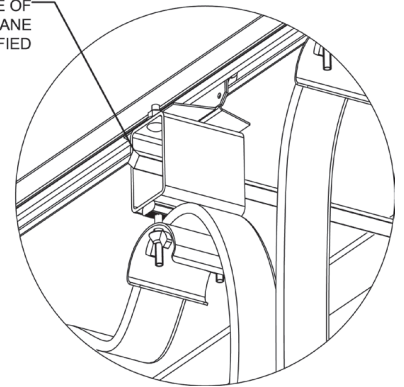

4.8 End Stop Installation

(1/2" & 13mm Open / Box End Wrench Required)

4.8.1 One end stop is required for power systems, two are required for control systems with a control trolley to stop the trolley from rolling out of the C-Track.

4.8.2 Install and tighten the end clamp and end stop(s) firmly in place. Torque fasteners for 11 ft.-lbs.

4.8.3 On pendant control lines and / or systems where the active travel is near the end of the channel. It is advisable to install a second stop.

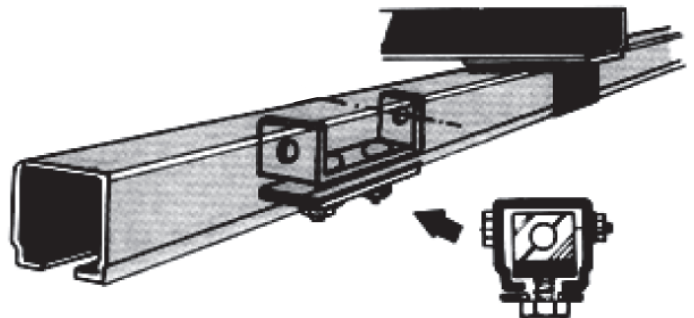

4.0 Installation

4.9 Installation of Cables

4.9.1 Before beginning the installation of cables, remove the cable clamping pad assemblies from the tow trolley, trolleys, and end clamp.

4.9.2 Install cables on the equipment per the pre-designed arrangement or the following rules:

4.9.2.1 Arrange cables with the larger cables (power cables) on top of stack (see diagram below). This provides a larger bending radius as well as improved heat dissipation. Since the top cable also takes more pulling force during operation, the larger conductor is better suited to handle this force. Note the specified cable loop depth and allowance for hookup.

4.9.2.2 Arrange the cable package with a width to height ratio of 3 or 4 to 1. Tall narrow cable stacks can be unstable during operation.

4.9.2.3 Arrange cables with a minimum of 50% of each cable surface under clamp pressure (See diagram below).

4.9.2.4 Install tow webbing if required, see section 4.9 for instructions.

4.9.2.5 After setting the cables to the proper loop depth and arranging the cables as designed, re-install the cable clamping pad assemblies. Be sure the smallest cables do not move when pulled.

4.9.2.6 As an alternative method, cable may be clamped in the saddles prior to installing the carriers on the channel.

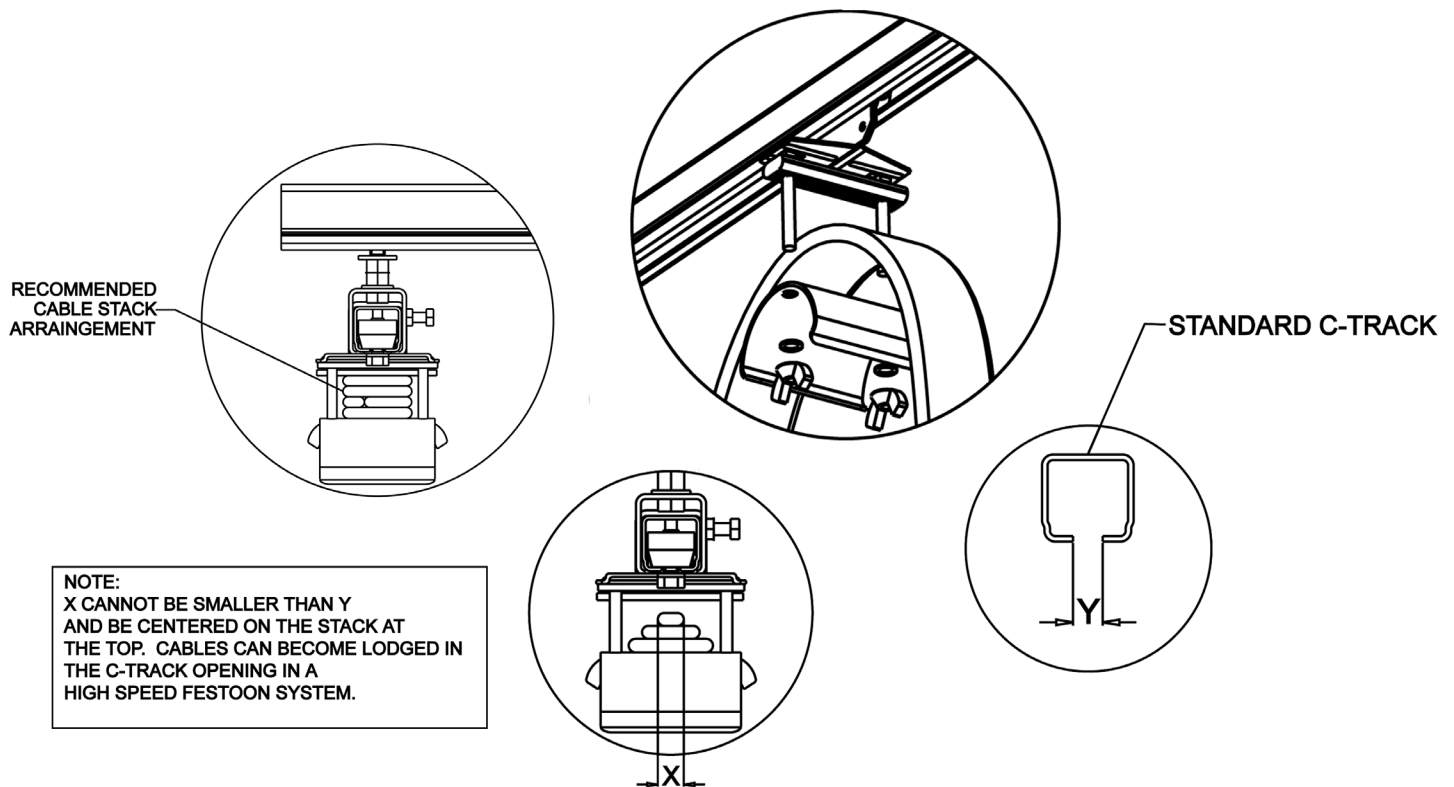

4.0 Installation

4.10 Tow Webbing Installation

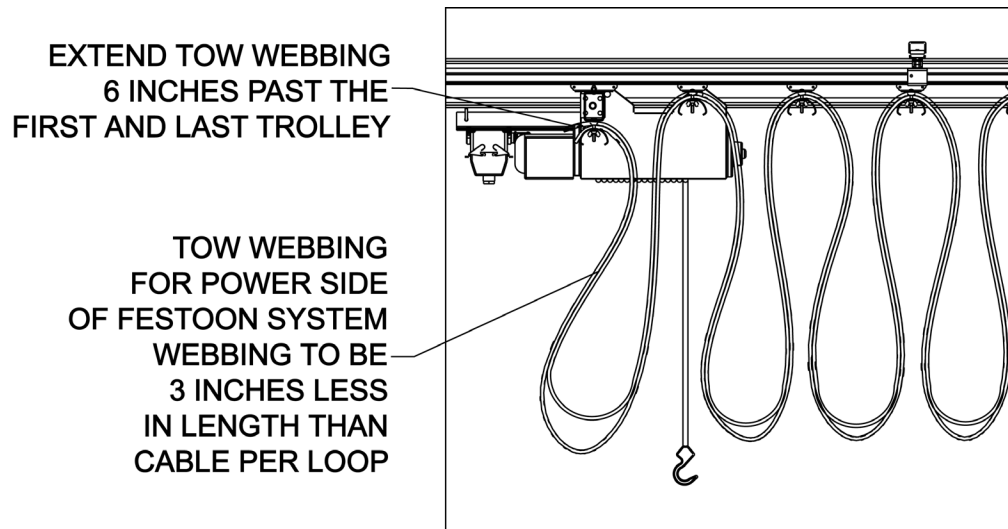

4.10.1 Tow webbing is used in both High Speed and Outdoor applications to reduce the shock and pulling tension on the electrical cable.

4.10.2 The tow webbing is installed on top of the electrical cable and held in place by the saddle on the cable trolley. The webbing length is generally 3 inches less than cable per loop of the length of the cable between cable trolleys. Contact factory for high speed applications to determine webbing length.

4.11 Tow Bar

4.11.1 The tow bar is fixed to the crane and is designed to engage tow box to move festoon system.

4.11.2 Install the tow bar on the crane or system that is to be electrified. Center and align tow bar with the Tow Trolley.

TOW BAR SHOULD BE CENTERED
TOP TO BOTTOM IN TOW BOX,
THIS ALLOWS THE CRANE OR HOIST
TO MOVE UP AND DOWN AND NOT DAMAGE
THE TOW TROLLEY OR C-TRACK

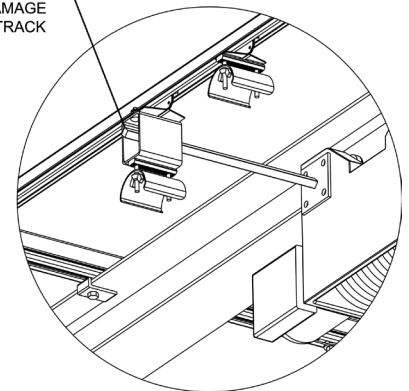

5.0 Operation

5.1 Pre-Operation Inspection

5.1.1 The festoon system is now installed. Prior to hookup and application of power, the carrier should be cycled manually, if possible.

5.1.1.1 Check for proper mounting of end clamps.

5.1.1.2 Check for obstructions of channel joints.

5.1.1.3 Check cable for proper loop depth, freedom of travel, and stretch-out.

5.1.2 On pendant systems, check for proper spacing of the pendant to the floor, and connect this cable in the junction box.

5.1.3 The cable connections now can be made to the power unit and the source, using the appropriate cable strain relief bushing(s).

5.2 Operation Instructions

5.2.1 Do not exceed the voltage or amperage rating of the cable. Overheating, fire, damages to equipment or personal injury could result.

5.2.2 Operate the festoon system within the electrical and mechanical limits it was intended.

6.0 Maintenance

6.1 Maintenance Instructions

6.1.1 All trolleys are lubricated and sealed for life, therefore no re-greasing is required. However, customers should conduct periodic inspections of the system. Determine the inspection intervals based on duty cycles and environment. The following checks are recommended during inspection:

6.1.1.1 Check all rollers for wear

6.1.1.2 Check tightness of all hardware. (See torque specifications)

6.1.1.3 Check cable clamps on all trolleys, making sure cables remain secure.

6.1.1.4 Inspect cable for any cuts or cracks.

6.1.1.5 Check channel for wear, and clear the running surface of any debris.